

.water .gas .hygienic .micro



bürkert
FLUID CONTROL SYSTEMS

.water .gas .hygienic .micro

Micro is a customer-oriented concept to combine the physical attributes of the application environments from your world. In this overview you will find a range of examples examining some of our core process competences. We believe we have intimate knowledge of significant insight into the application environments which traverse a spectrum of industries from clinical diagnostic technology, DNA synthesizing and medical instruments to high-throughput lab automation, industrial ink jet and analytical instruments.

Our aim is to collaborate with you in the real physics of precision dosing, batching, mixing, distributing and sample and reagent preparation in quantities from sub micro-liters to liters per minute. Whether you are using aggressive mixtures of solvents or reagents, handle critical samples or just neutral liquids, we know how to control your fluids.

Everyone in our organisation is committed to the process of listening carefully to your needs, in order to provide you with a thoroughly customised solution in your daily application language. The inherent expertise available within the Bürkert organisation exists to make your life simpler. Our versatile systems highlight our continuous customer-oriented innovation and are developed to simplify the MicroFluidics world and save you time.

An otherwise unattainable synergy of hardworking valve elements, sensors, networked communication and manifold experience provide a true single source of remarkable attractive systems which offer you peace of mind, process safety and joy of use.

In the MicroFluidics world where compactness, smart communication, dead legs, cross-contamination and validation are everyday concerns we provide process efficiency and higher yields by offering you unlimited process modularity.

Content

- 5 _____ Company Profile
- 6 _____ Products and Systems
- 9 _____ Micro
- 12 _____ Clinical Diagnostics
- 15 _____ Life Science Lab
- 16 _____ Scientific Research Lab
- 20 _____ Automated Analytics
- 23 _____ Intensive Care Technology
- 24 _____ Medical Instruments
- 27 _____ Industrial Applications
- 30 _____ Contacts at Bürkert



Welcome to the Fascinating World of Fluid Control Systems.

Measurement and control: When it comes to working with fluids and gases, we are at your side—as a manufacturer of sophisticated products, as a problem-solver with an eye for the big picture, and as a partner offering you reliable advice. Since we started in 1946, we have developed into one of the world's leading suppliers of Fluid Control Systems. At the same time we have kept our status as a family-run business with a foundation of strong basic values to highlight the way we think and act.

What we build on: Experience

We bring together over 60 years of applied knowledge, theoretical expertise and all-round experience in the field of Fluid Control Systems. We at Bürkert have always taken care to ensure that the insights gained in working on innumerable products and projects are passed on, not only among our over 2,400 employees in various locations and divisions, but also from one Bürkert generation to the next. We focus all our curiosity, passion and commitment on one goal: to provide solutions that take your company that essential step forward.

What sets us apart: Closeness

To engineer expert solutions with added value, you need to be close to your customers and their problems—as we are. For us at Bürkert, closeness means personal closeness. We listen to your every word and do everything in our power to devise and implement the best solution for your needs. Closeness also applies in a technical sense. We know exactly what role our products play in your complex processes. Last but not least, we understand closeness in a geographical sense: Our global presence with over 35 branches and seven production sites allows our customers to draw on technological innovations from all over the world.

What drives us forward: Courage

We aim to surpass your expectations. To make it happen, one quality is vital: courage. The courage not just to look forward but to move forward, to challenge conventional wisdom, to do things differently, to tackle problems others think are impossible and to never give up when the going gets tough. We demonstrate this courage time and again. Our wealth of experience is the solid platform on which our courage is based. It allows us to turn courage into creativity, convert off-beat ideas into surprising innovations and put together individual components to create completely new systems that open up unexpected possibilities.



Good from Every Angle: Our Products.

Fluids are fascinating media. And it is this very fascination with liquids and gases that drives us to develop ever new devices that can handle them even better. We are one of the few suppliers on the market to cover the complete control loop. Our current product range extends from solenoid valves through process and analytical valves to pneumatic actuators and sensors.

To meet our customers' ever-changing demands, the people at our four research and development centers permanently work on improving both our individual products and our range as a whole. Products that solve a particular problem perfectly, that offer a true value-added benefit over other products, that meet specific industry requirements.

In the Micro arena we have worked continuously to be involved in the specifications and requirements and special interest groups that push the industry towards higher standards and improved value for their customers. We believe we have done the work which allows you to have peace of mind. When you specify Bürkert you know you will receive real, verifiable consistent quality ... quickly.

Innovative, Value-added Solutions Combine the Best of All Worlds.

You can see Bürkert as a supplier who simply provides you with good products. We are happy to fill that role, but what really makes us proud is when you see us as a partner who joins you in getting the job done, however complex. Even if the problem seems irresolvable, challenge us, put our courage to the test it: Is the tough challenges that drive us, moving you and us forward.

We are at your side at all times with a seamless range of services, from consulting and engineering through installation, testing and after-sales service. No matter if it is an individual component or a groundbreaking new system for the entire process of measurement and control.

Expertise in low-volume liquid handling, batching and mixing, precision dosing, bioreactors, chromatography and clinical diagnostic instruments to name a few examples allows us to help in your language. Speaking a common language eases communication and lays the foundation for your success.

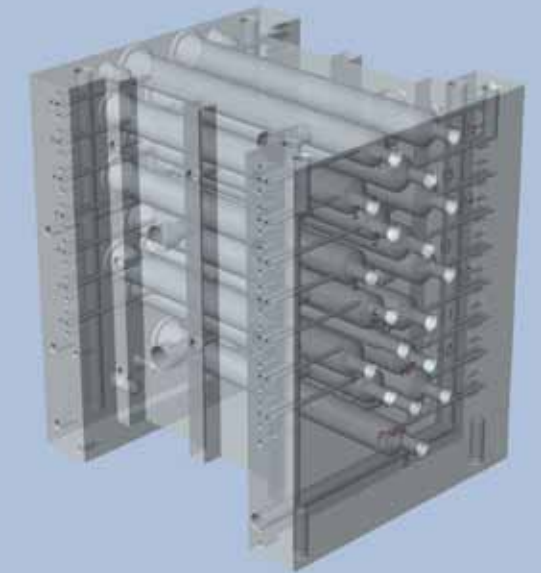
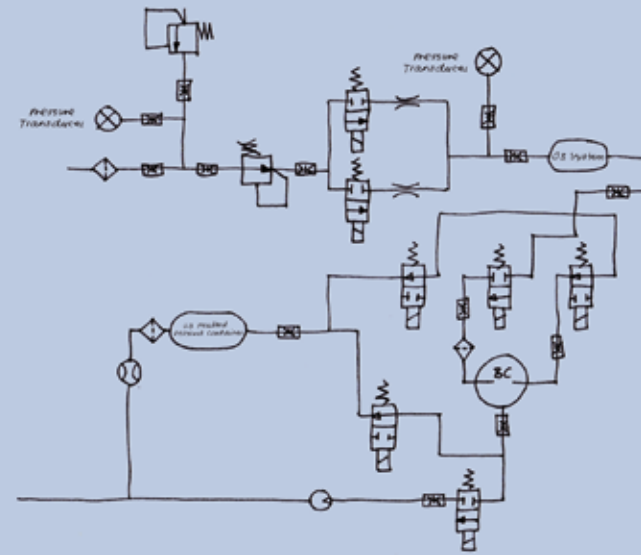

IDEAS & CONSULTING

SIMULATION & DEVELOPMENT

SYSTEM

PROTOTYPE

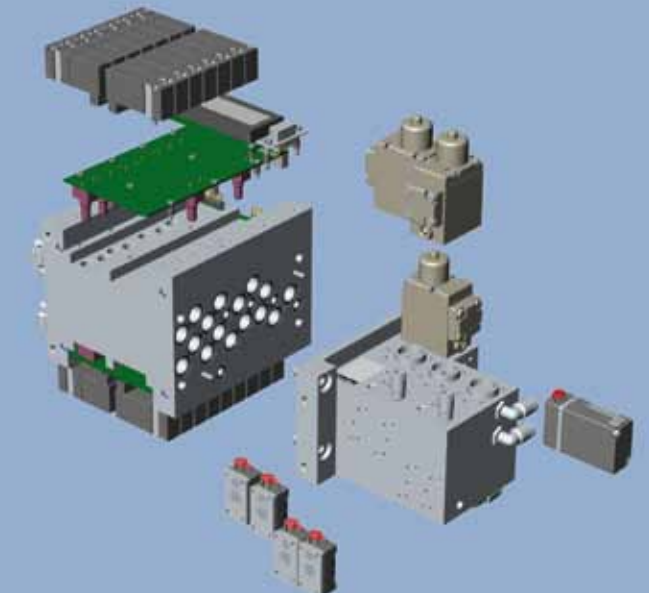

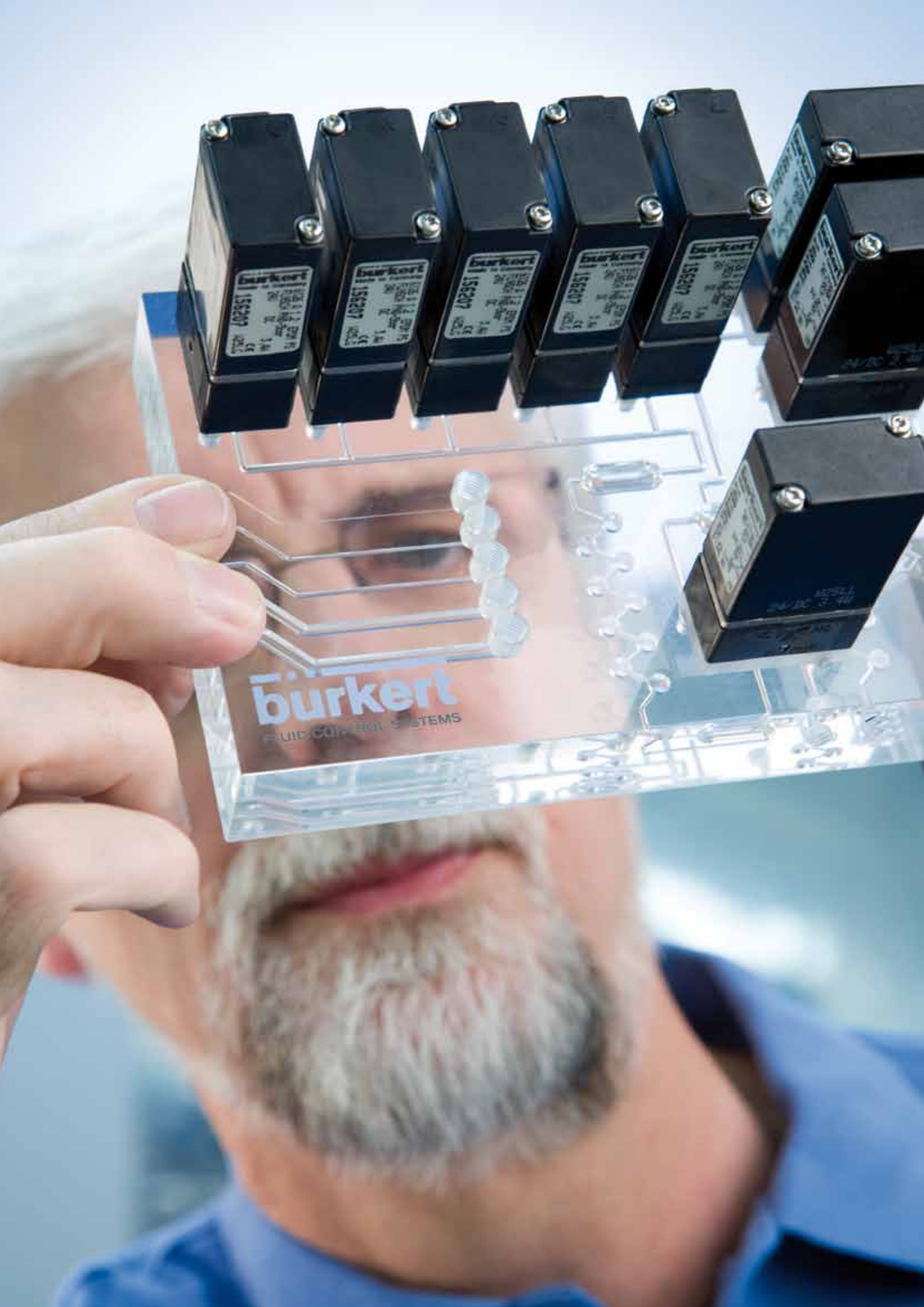

We Help Your Ideas Flow.

We are proficient in the handling of fluids where dead legs, internal volume, chemical resistance and precision are paramount.

Ultra-pure water, aggressive solvents, biochemical substrates, highly concentrated acids or lyes, different viscosities, fast drying industrial inks or crystallizing fluids present a wide range of flow challenges that we understand.

Active in Micro for more than 20 years, we have gained wide experiences in the production of suitable components and systems for this market. Clean production facilities, an in-house tool-shop and dedicated engineering specialists provide you with solutions that exceed your expectations. We apply technologies such as rapid prototyping, 3D CAD design and simulations as well as multilayer manifolds to ensure that you are always one step ahead of your competition.

We are proven partners who can deliver optimised solutions through both listening to you and intelligent design.

Our market leadership built by constant innovation and pioneering design offers reliability, superior accuracy and unsurpassed total performance.



A middle-aged man with grey hair and a beard, wearing a light blue button-down shirt, stands in a factory or laboratory. He is holding a black microfluidic chip with orange ports. The background is a blurred industrial environment with metal structures and lights.

EXPERIENCE

There are things which are not inherently yours. You have to gather them bit by bit. You receive them from others. And you constantly have to acquire them anew. That is what makes them so valuable. Experience is one of those things. For instance, because of our many years of experience with MicroFluidics, we can provide our extensive services to you—from consulting, development, and 3D CAD simulating to testing and after-sales service. Whether individual product solutions or a pioneering new system for the entire control process: Benefit from our experience!

In Vitro Veritas.

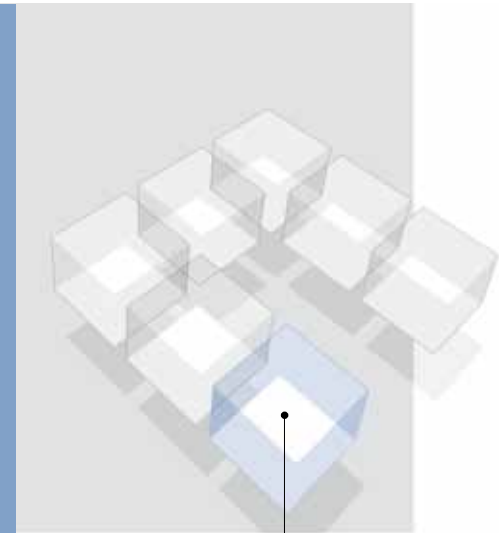

True walkaway automation with Bürkert technology performs testing more efficiently and cost-effectively.

In clinical diagnostics, where throughput and reliability are key drivers, Bürkert provides peace of mind, fast.

Blood, serum or urine analysis requires expertise in sample and reagent handling, flushing and waste treatment.

As your established partner, we can optimize integration of specific system solutions for mixing, distribution or dosing.

From concept to production Bürkert is committed to the success of your latest blockbuster instrument.

Bürkert provides cutting edge solutions for In-vitro Diagnostic applications.



Multilayer manifold for immunoassay system

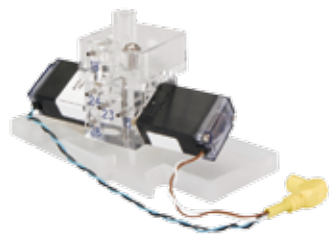

2-station manifold type 0127 for clinical diagnostics



5-station manifold type 6606 for rinsing cycle





Track Down the Secrets of Life.

Today's advanced life science research in fields such as molecular diagnostics is destined to become the standard diagnostic method of tomorrow. Bürkert is ready to help you tackle the future.

Biochips and DNA analysis are leading edge technologies which will improve early diagnosis, protect us from pandemics and identify the solutions for currently incurable diseases.

High throughput systems not only enable genome sequencing but are also the basis for faster and more efficient drug development.

Bürkert's expertise in precision dosing, ultra-short response times, low internal volumes, chemically inert materials for unaltered test results as well as cross contamination free components and manifolds all aid in effective design of your lab automation devices.

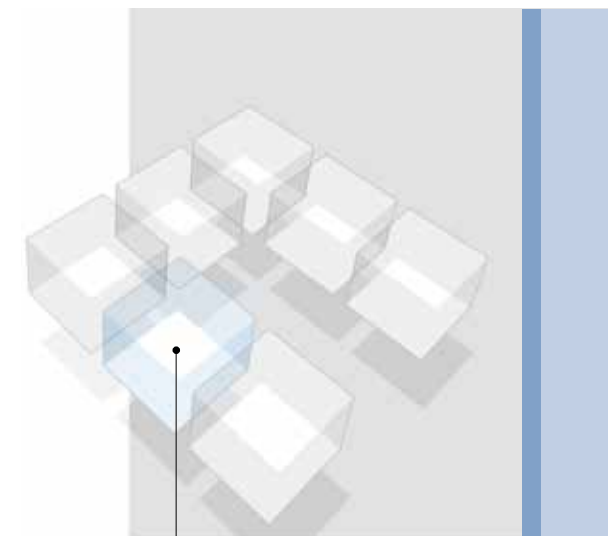

Widely acclaimed lab automation facilitated by Bürkert Fluid Control Systems improves total systems reliability.

Micro deals with the smallest amounts of fluids precisely.



Compact 16-station dosing head type 6650



16-fold precision pressure controller with I²C-bus



25-station dosing and mixing unit for DNA synthesizer

Trace elements.

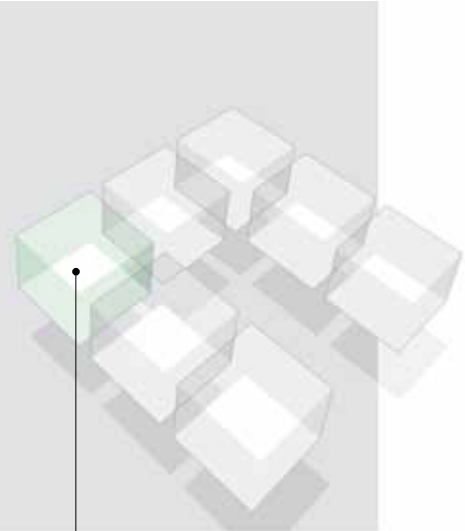

Intelligent integrated Bürkert system solutions ensure optimum performance and accuracy for your research instrumentation.

Material research, trace analysis or analytical chemistry require the analysis of elements. A firm partnership which covers the entire process sequence is vital when you are in the world of "ppb" and "ppt".

Working hand-in-hand with our clients we have developed some of the most advanced equipment in the industry. From AAS and ICP devices to chromatography systems Bürkert always collaborates to produce highly integrated systems.

Combining actuators, sensors, electronics, predictive control and software with experience and the courage to go a step further produces three benefits:

High performance, pin-point accuracy and customer satisfaction.

We help you explore the boundaries of science.



Collector for SMB chromatography



Gas control box for AAS



ICP control unit





COURAGE

Those who only work toward optimizing things that already exist will eventually reach the limits—technically, financially, or personally. In order to overcome these limits, courage is needed: The courage to be different and trust one's own ideas; the courage to venture into the unknown, searching for new ways to develop products that have never existed before. We have this courage. By pooling and utilizing our competencies across all sectors, you benefit from our cumulative knowledge of MicroFluidic systems—whether it is in Clinical Diagnostics or Industrial Analytics.

Automate Your Quality Control.

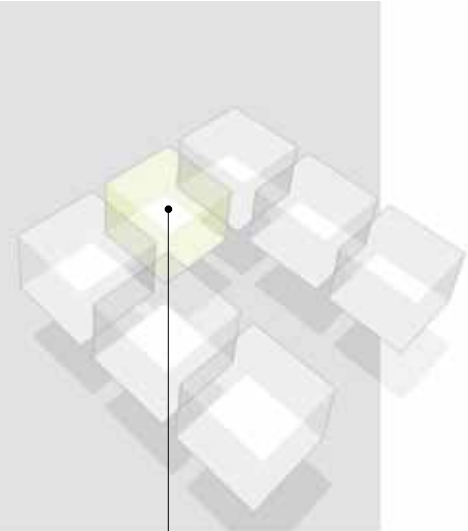

Automated quality control makes life easier and provides better process efficiency.

Environmental monitoring, waste water analysis, food quality control, paper production monitoring systems or viscosity determination in petrochemistry are just a few examples of today's applications that require intelligent and automated on-site analytics.

Automation of standard operations like titration, defined sample points or precision reagent dosing calls for expertise in integrated fluid control systems. This is particularly the case when dealing with small sample or reagent volumes of potentially aggressive liquids together with challenging specifications as regards precision and repeat accuracy.

We love to combine our component expertise and system technology know-how to develop a solution that exactly fits your needs.

Reliable and precise low volume liquid handling is our business, ... even in tough environments.



Unit for on-site phosphate measurement



viscosity measurement



titration



Keeping you alive.

Emergency situations demand trust in the people who are there to help you and also in the technology which now surrounds us in critical situations.

Just as an anaesthetist or a surgeon needs practice and experience, we have over the years gathered expertise in a wide range of intensive care applications, from respirator technology and anaesthesia to insufflators for keyhole surgery.

We have direct experience in a range of applications from gas mixing and distribution to systems for cleaning and leak testing endoscopes. For every client, fully customized products and systems are created from our range of standard technology. Fast and clean facilities house both engineering and tool design. Rapid prototyping and 3D printing allow you to integrate complex ideas and modules into your next great idea.

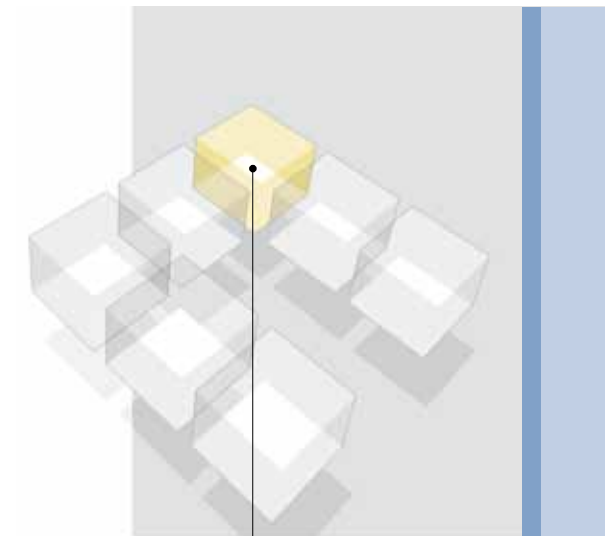

*Trust in health professionals.
Trust in the technology.*

Just as for a patient during surgery we put your success at the number one priority.



*Endoscope disinfection
and leak test system*



*High flow-low pressure
3/2-way valve for respirators*



*Flow control block for
insufflators*

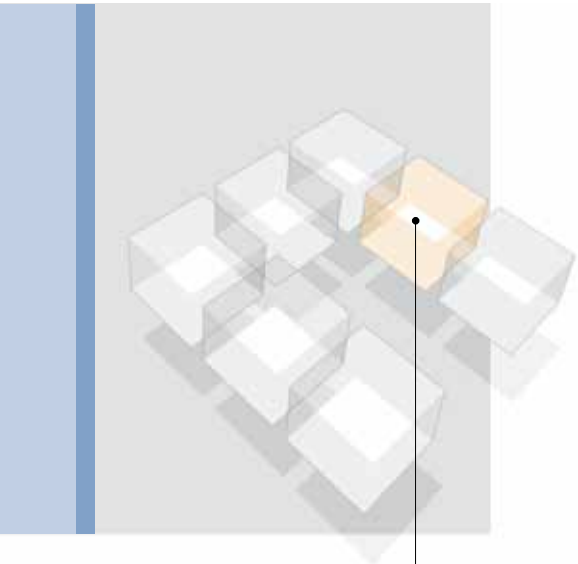

*Bürkert is embedded
in many medical systems.*

Technology to Trust In.

A visit to the dentist cannot be delayed forever but Bürkert may be able to offer much less painful treatment with its cutting-edge innovations inside your dentists chair.

Not only dental chairs but also haemodialysis instruments, home care respirators, sterilizers and lithotripters probably contain a little bit of Bürkert.

We disinfect, cool, handle dialysate, pump, pressurise and flush in environments which demand low maintenance, low noise generation, media isolation, and certified medical grade materials.

System technology including tools, molded parts, sensor technology, valves and control electronics have sprung from numerous co-developments, so next time you visit the dentist ... relax ... Bürkert is inside.

*Bürkert technology in dental chairs: out of sight—but there for
your comfort.*



*Water supply and conditioning
unit in dental chairs*



*Air and water flow control
for dental instruments*



*Gas control unit for home
care ventilators*





Meeting Industrial Requirements.

Across industries, from industrial inkjet, optical disc production, lubricant or glue dosing, car wash stations to commercial appliances, increasing demands are made on low-volume liquid handling. One key driver is a trend for stronger or higher concentrated chemicals.

Our custom wetted parts are guaranteed for high concentrations, whether of a detergent, a reagent or an aggressive solvent. The special challenges of robustness and reliability, even in extreme contexts, motivate us to create the right solution for you.

Precision, reliability and material security is only part of the equation in building superlative systems. Closeness is key. We form a strong team with you where ever you are.

Global expertise ... locally.

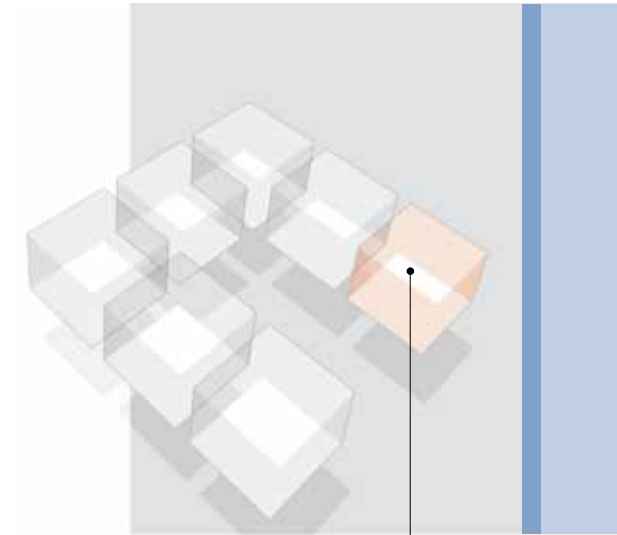

A wealth of knowledge and industrial experience is better than any chemical resistance chart.

We work in a range of industries and can provide eggsactly what you need.



Ink supply and rinsing unit for industrial inkjet



Carrying handle for water-cooled core drill



Seal gas block for turbo molecular pumps



CLOSENESS

There are things we simply take for granted. Only when they are gone, do we realize how important these things really were. This applies in particular to closeness.

Without closeness, it is very difficult to build relationships and a good understanding of one another. As an established medium-sized company, we know that. And that is why we are always there for you. Working with you, we develop the best possible solutions for your projects in the area of MicroFluidics. Our global presence in 35 locations enables us to press ahead with technical innovations for our customers around the world.

Bürkert – Close to You

For up-to-date addresses
please visit us at
www.burkert.com.



Bürkert Fluid Control Systems

Christian-Bürkert-Straße 13-17
74653 Ingelfingen
Deutschland

Tel.: +49 (0) 7940/10-0
Fax: +49 (0) 7940/10-204
info@burkert.com
www.burkert.com

